



ProSTUD® Drywall Framing System



 STEELFRAMINGASSOCIATION.ORG	<p>NONSTRUCTURAL CERTIFIED CODE COMPLIANT TO</p> <ul style="list-style-type: none"> ✓ IBC 2009 ✓ ASTM C645 ✓ ASTM A1003/A1003M ✓ ASTM B117 ✓ AISI S220 	 QUALITY ASSURANCE PROGRAM #21-144215
Steel Framing Industry Association—Service to the Industry		



Product Data – ProSTUD & ProTRAK

Section Properties
Section Properties Table Notes

- 1. Section properties were determined in accordance with AISI S100-07, North American Specification for Design of Cold-Formed Steel Structural Members.
2. Effective properties incorporate the strength increase from the cold work of forming as applicable per AISI A7.2.
3. Tabulated gross properties including torsional properties are based on full-unreduced cross section of the studs, away from punchouts.
4. For deflection calculations, use the effective moment of inertia.
5. Allowable moment includes cold-work of forming.
6. Web depth for track sections is equal to the nominal height plus 2 times the design thickness plus the bend radius. Hems on non-structural rack sections are ignored.
7. Allowable moment is taken as the lowest value based on local or distortional buckling. Distortional buckling strength is based on a k-phi = 0.

Non-Structural (PS) ProSTUD® Section Properties

Table with columns: Member, Design Thickness (in), Fy (ksi), Area (in²), Weight (lb/ft), Ix (in⁴), Rx (in), Iy (in⁴), Ry (in), Ae (in²), Ix (in⁴), Sx (in³), Ma (in-lbs), VAg (lb), Vnet (lb), Jx1000 (in⁴), Cw (in⁶), Xc (in), Ro (in), Lc (in), Lu (in)

- 1. Web-height to thickness ratio exceeds 200. Web Stiffeners are required at all support points and concentrated loads.
2. Web-depth to thickness ratio exceeds 260. Web stiffeners are required at all bearing and intermediate locations, and no web holes are permitted in non-composite conditions

For additional information, please call (305) 634-0012 or visit our website www.ramsteel framing.com



Product Data – ProSTUD & ProTRAK

Section Properties

Section Properties Table Notes

1. Section properties were determined in accordance with AISI S100-07, North American Specification for Design of Cold-Formed Steel Structural Members.
2. Effective properties incorporate the strength increase from the cold work of forming as applicable per AISI A7.2.
3. Tabulated gross properties including torsional properties are based on full-unreduced cross section of the tracks.
4. For deflection calculations, use the effective moment of inertia.
5. Allowable moment includes cold-work of forming.
6. Web depth for track sections is equal to the nominal height plus 2 times the design thickness plus the bend radius. Hems on non-structural rack sections are ignored.

Non-Structural (PT) ProTRAK® (1-1/4" Leg) Section Properties

Section	Design Thickness (in)	F (ksi)	Gross Section Properties					Effective Section Properties at Fy							Torsional Properties			
			Area Weight Ix (in2) (lb/ft) (in4)			Rx (in)	Iy (in4)	Ry (in)	Ae (in2)	Ix (in4)	Sx Ma Vag (in3) (in-lbs) (lb)		Jx1000 Cw (in4) (in6)		Xo (in)	Ro (in)	β	
162PDT125-15	0.0158	50	0.065	0.22	0.034	0.717	0.011	0.412	0.020	0.021	0.016	464	222	0.00542	0.006	-0.881	1.208	0.468
250PDT125-15	0.0158	50	0.079	0.27	0.085	1.038	0.013	0.400	0.020	0.059	0.024	724	143	0.00657	0.015	-0.771	1.353	0.675
350PDT125-15 ¹	0.0158	50	0.095	0.32	0.181	1.383	0.014	0.383	0.021	0.116	0.034	1022	101	0.00789	0.031	-0.678	1.587	0.818
362PDT125-15 ¹	0.0158	50	0.097	0.33	0.196	1.425	0.014	0.381	0.021	0.125	0.035	1059	98	0.00805	0.034	-0.668	1.619	0.830
400PDT125-15 ¹	0.0158	50	0.103	0.35	0.247	1.550	0.014	0.374	0.021	0.153	0.039	1171	89	0.00854	0.043	-0.640	1.718	0.861
550PDT125-15 ²	0.0158	50	0.126	0.43	0.524	2.036	0.015	0.350	0.021	0.290	0.054	1611	64	0.01052	0.089	-0.549	2.137	0.934
600PDT125-15 ²	0.0158	50	0.134	0.46	0.646	2.194	0.016	0.343	0.021	0.350	0.059	1762	59	0.01117	0.108	-0.524	2.282	0.947
162PDT125-19	0.0200	50	0.082	0.28	0.043	0.719	0.014	0.411	0.031	0.028	0.024	718	421	0.01099	0.007	-0.879	1.207	0.470
250PDT125-19	0.0200	50	0.100	0.34	0.108	1.039	0.016	0.400	0.032	0.078	0.038	1136	289	0.01333	0.018	-0.769	1.353	0.677
350PDT125-19	0.0200	50	0.120	0.41	0.230	1.384	0.018	0.382	0.032	0.176	0.053	1593	206	0.01599	0.040	-0.676	1.587	0.819
362PDT125-19	0.0200	50	0.122	0.42	0.249	1.426	0.018	0.380	0.032	0.191	0.055	1650	199	0.01633	0.043	-0.666	1.619	0.831
400PDT125-19	0.0200	50	0.130	0.44	0.312	1.551	0.018	0.374	0.032	0.232	0.061	1822	180	0.01733	0.054	-0.638	1.718	0.862
550PDT125-19 ²	0.0200	50	0.160	0.54	0.663	2.037	0.020	0.349	0.032	0.420	0.083	2483	130	0.02133	0.112	-0.547	2.137	0.934
600PDT125-19 ²	0.0200	50	0.170	0.58	0.819	2.195	0.020	0.342	0.032	0.508	0.091	2717	119	0.02266	0.137	-0.523	2.282	0.948
162PDT125-30	0.0312	33	0.128	0.44	0.067	0.722	0.022	0.409	0.080	0.054	0.048	951	610	0.04168	0.011	-0.872	1.204	0.475
250PDT125-30	0.0312	33	0.156	0.53	0.169	1.042	0.025	0.397	0.084	0.140	0.087	1713	832	0.05054	0.029	-0.763	1.351	0.681
350PDT125-30	0.0312	33	0.187	0.64	0.359	1.386	0.027	0.380	0.087	0.304	0.141	2789	781	0.06066	0.062	-0.671	1.586	0.821
362PDT125-30	0.0312	33	0.191	0.65	0.389	1.428	0.027	0.378	0.087	0.330	0.149	2938	755	0.06193	0.067	-0.661	1.619	0.833
400PDT125-30	0.0312	33	0.203	0.69	0.489	1.553	0.028	0.371	0.088	0.417	0.172	3407	683	0.06573	0.084	-0.633	1.718	0.864
550PDT125-30	0.0312	33	0.249	0.85	1.036	2.038	0.030	0.347	0.089	0.880	0.218	4306	495	0.08091	0.174	-0.543	2.138	0.935
600PDT125-30	0.0312	33	0.265	0.90	1.278	2.196	0.031	0.340	0.090	1.074	0.240	4737	454	0.08597	0.212	-0.519	2.282	0.948
162PDT125-33	0.0346	33	0.142	0.48	0.075	0.723	0.024	0.409	0.095	0.063	0.056	1104	677	0.05683	0.012	-0.870	1.203	0.477
250PDT125-33	0.0346	33	0.173	0.59	0.188	1.043	0.027	0.397	0.102	0.160	0.100	1972	1024	0.06891	0.032	-0.762	1.351	0.682
350PDT125-33	0.0346	33	0.207	0.70	0.399	1.387	0.030	0.380	0.105	0.346	0.161	3189	1024	0.08272	0.068	-0.669	1.586	0.822
362PDT125-33	0.0346	33	0.212	0.72	0.432	1.429	0.030	0.377	0.105	0.375	0.170	3358	1024	0.08444	0.074	-0.659	1.618	0.834
400PDT125-33	0.0346	33	0.225	0.77	0.542	1.554	0.031	0.371	0.106	0.473	0.197	3887	931	0.08962	0.093	-0.632	1.718	0.865
550PDT125-33	0.0346	33	0.276	0.94	1.149	2.039	0.033	0.347	0.108	1.011	0.261	5157	675	0.11033	0.192	-0.542	2.138	0.936
600PDT125-33	0.0346	33	0.294	1.00	1.418	2.197	0.034	0.339	0.109	1.237	0.287	5681	619	0.11723	0.234	-0.517	2.282	0.949

1. Web-height to thickness ratio exceeds 200. Web Stiffeners are required at all support points and concentrated loads.
2. Web-depth to thickness ratio exceeds 260. Web stiffeners are required at all bearing and intermediate locations, and no web holes are permitted in non-composite conditions

For additional information, please call (305) 634-0012 or visit our website www.ramsteel framing.com



Product Data – ProSTUD & ProTRAK

Section Properties

Section Properties Table Notes

1. Section properties were determined in accordance with AISI S100-07, North American Specification for Design of Cold-Formed Steel Structural Members.
2. Effective properties incorporate the strength increase from the cold work of forming as applicable per AISI A7.2.
3. Tabulated gross properties including torsional properties are based on full-unreduced cross section of the tracks.
4. For deflection calculations, use the effective moment of inertia.
5. Allowable moment includes cold-work of forming.
6. Web depth for track sections is equal to the nominal height plus 2 times the design thickness plus the bend radius. Hems on non-structural rack sections are ignored.

Non-Structural (PT) ProTRAK® (1-1/4" Leg) Section Properties

Section	Design Thickness (in)	F (ksi)	Gross Section Properties						Effective Section Properties at Fy						Torsional Properties				
			Area Weight Ix (in ² (lb/ft) (in ⁴))		Rx (in)	Iy (in ⁴)	Ry (in)	Ae (in ²)	Ix (in ⁴)	Sx (in ³)	Ia (in ⁴)	Vag (in-lbs) (lb)	Jx1000 (in ⁴)	Cw (in ⁶)	Xo (in)	Ro (in)	β		
162PDT125-15	0.0158	50	0.065	0.22	0.034	0.717	0.011	0.412	0.020	0.021	0.016	464	222	0.00542	0.006	-0.881	1.208	0.468	
250PDT125-15	0.0158	50	0.079	0.27	0.085	1.038	0.013	0.400	0.020	0.059	0.024	724	143	0.00657	0.015	-0.771	1.353	0.675	
350PDT125-15 ¹	0.0158	50	0.095	0.32	0.181	1.383	0.014	0.383	0.021	0.116	0.034	1022	101	0.00789	0.031	-0.678	1.587	0.818	
362PDT125-15 ¹	0.0158	50	0.097	0.33	0.196	1.425	0.014	0.381	0.021	0.125	0.035	1059	98	0.00805	0.034	-0.668	1.619	0.830	
400PDT125-15 ¹	0.0158	50	0.103	0.35	0.247	1.550	0.014	0.374	0.021	0.153	0.039	1171	89	0.00854	0.043	-0.640	1.718	0.861	
550PDT125-15 ²	0.0158	50	0.126	0.43	0.524	2.036	0.015	0.350	0.021	0.290	0.054	1611	64	0.01052	0.089	-0.549	2.137	0.934	
600PDT125-15 ²	0.0158	50	0.134	0.46	0.646	2.194	0.016	0.343	0.021	0.350	0.059	1762	59	0.01117	0.108	-0.524	2.282	0.947	
162PDT125-19	0.0200	50	0.082	0.28	0.043	0.719	0.014	0.411	0.031	0.028	0.024	718	421	0.01099	0.007	-0.879	1.207	0.470	
250PDT125-19	0.0200	50	0.100	0.34	0.108	1.039	0.016	0.400	0.032	0.078	0.038	1136	289	0.01333	0.018	-0.769	1.353	0.677	
350PDT125-19	0.0200	50	0.120	0.41	0.230	1.384	0.018	0.382	0.032	0.176	0.053	1593	206	0.01599	0.040	-0.676	1.587	0.819	
362PDT125-19	0.0200	50	0.122	0.42	0.249	1.426	0.018	0.380	0.032	0.191	0.055	1650	199	0.01633	0.043	-0.666	1.619	0.831	
400PDT125-19	0.0200	50	0.130	0.44	0.312	1.551	0.018	0.374	0.032	0.232	0.061	1822	180	0.01733	0.054	-0.638	1.718	0.862	
550PDT125-19 ²	0.0200	50	0.160	0.54	0.663	2.037	0.020	0.349	0.032	0.420	0.083	2483	130	0.02133	0.112	-0.547	2.137	0.934	
600PDT125-19 ²	0.0200	50	0.170	0.58	0.819	2.195	0.020	0.342	0.032	0.508	0.091	2717	119	0.02266	0.137	-0.523	2.282	0.948	
162PDT125-30	0.0312	33	0.128	0.44	0.067	0.722	0.022	0.409	0.080	0.054	0.048	951	610	0.04168	0.011	-0.872	1.204	0.475	
250PDT125-30	0.0312	33	0.156	0.53	0.169	1.042	0.025	0.397	0.084	0.140	0.087	1713	832	0.05054	0.029	-0.763	1.351	0.681	
350PDT125-30	0.0312	33	0.187	0.64	0.359	1.386	0.027	0.380	0.087	0.304	0.141	2789	781	0.06066	0.062	-0.671	1.586	0.821	
362PDT125-30	0.0312	33	0.191	0.65	0.389	1.428	0.027	0.378	0.087	0.330	0.149	2938	755	0.06193	0.067	-0.661	1.619	0.833	
400PDT125-30	0.0312	33	0.203	0.69	0.489	1.553	0.028	0.371	0.088	0.417	0.172	3407	683	0.06573	0.084	-0.633	1.718	0.864	
550PDT125-30	0.0312	33	0.249	0.85	1.036	2.038	0.030	0.347	0.089	0.880	0.218	4306	495	0.08091	0.174	-0.543	2.138	0.935	
600PDT125-30	0.0312	33	0.265	0.90	1.278	2.196	0.031	0.340	0.090	1.074	0.240	4737	454	0.08597	0.212	-0.519	2.282	0.948	

1. Web-height to thickness ratio exceeds 200. Web Stiffeners are required at all support points and concentrated loads.
2. Web-depth to thickness ratio exceeds 260. Web stiffeners are required at all bearing and intermediate locations, and no web holes are permitted in non-composite conditions

For additional information, please call (305) 634-0012 or visit our website www.ramsteel framing.com



Product Data – ProSTUD & ProTRAK

Section Properties

Section Properties Table Notes

1. Section properties were determined in accordance with AISI S100-07, North American Specification for Design of Cold-Formed Steel Structural Members.
2. Effective properties incorporate the strength increase from the cold work of forming as applicable per AISI A7.2.
3. Tabulated gross properties including torsional properties are based on full-unreduced cross section of the tracks.
4. For deflection calculations, use the effective moment of inertia.
5. Allowable moment includes cold-work of forming.
6. Web depth for track sections is equal to the nominal height plus 2 times the design thickness plus the bend radius. Hems on non-structural rack sections are ignored.

Non-Structural (PT) ProTRAK® (1-1/2" Leg) Section Properties

Section	Design	F Thickn (in) (ksi)	Gross Section Properties						Effective Section Properties at Fy					Torsional Properties				
			Area (in ²)	Weight (lb/ft) (in ⁴)	Rx (in)	Iy (in ⁴)	Iy (in ⁴)	Ry (in)	Ae (in ²)	k (in ⁴)	Sx (in ³)	Ma (in-lbs)	Vag (lb)	Jx1000 (in ⁴) (in ⁶)	Xo (in)	Ro (in)	β	
162PDT150-15	0.0158	50	0.073	0.25	0.039	0.731	0.018	0.497	0.020	0.023	0.015	460	222	0.00608	0.009	-1.110	1.419	0.388
250PDT150-15	0.0158	50	0.087	0.30	0.098	1.062	0.021	0.489	0.020	0.061	0.024	723	143	0.00723	0.024	-0.985	1.529	0.585
350PDT150-15 ¹	0.0158	50	0.103	0.35	0.206	1.417	0.023	0.473	0.021	0.120	0.034	1024	101	0.00854	0.051	-0.877	1.732	0.744
362PDT150-15 ¹	0.0158	50	0.105	0.36	0.223	1.460	0.023	0.470	0.021	0.129	0.035	1061	98	0.00871	0.056	-0.865	1.761	0.759
400PDT150-15 ¹	0.0158	50	0.111	0.38	0.279	1.589	0.024	0.464	0.021	0.158	0.039	1175	89	0.00920	0.070	-0.832	1.852	0.798
550PDT150-15 ²	0.0158	50	0.134	0.46	0.585	2.087	0.026	0.438	0.021	0.307	0.054	1628	64	0.01117	0.145	-0.722	2.251	0.897
600PDT150-15 ²	0.0158	50	0.142	0.48	0.719	2.249	0.026	0.430	0.021	0.363	0.059	1774	59	0.01183	0.177	-0.692	2.392	0.916
162PDT150-19	0.0200	50	0.092	0.31	0.050	0.733	0.023	0.496	0.031	0.030	0.024	721	421	0.01233	0.012	-1.107	1.418	0.390
250PDT150-19	0.0200	50	0.110	0.37	0.124	1.063	0.026	0.488	0.032	0.084	0.038	1129	289	0.01466	0.030	-0.983	1.528	0.586
350PDT150-19	0.0200	50	0.130	0.44	0.261	1.418	0.029	0.472	0.032	0.183	0.053	1593	206	0.01733	0.065	-0.875	1.732	0.745
362PDT150-19	0.0200	50	0.132	0.45	0.283	1.461	0.029	0.470	0.032	0.196	0.055	1652	199	0.01766	0.070	-0.863	1.761	0.760
400PDT150-19	0.0200	50	0.140	0.48	0.354	1.590	0.030	0.463	0.032	0.238	0.061	1826	180	0.01866	0.088	-0.830	1.852	0.799
550PDT150-19 ²	0.0200	50	0.170	0.58	0.741	2.088	0.032	0.437	0.032	0.457	0.084	2527	130	0.02266	0.183	-0.721	2.251	0.898
600PDT150-19 ²	0.0200	50	0.180	0.61	0.910	2.249	0.033	0.429	0.033	0.530	0.092	2741	119	0.02399	0.224	-0.691	2.392	0.917
162PDT150-30	0.0312	33	0.144	0.49	0.078	0.737	0.035	0.494	0.080	0.059	0.050	983	610	0.04674	0.018	-1.101	1.414	0.394
250PDT150-30	0.0312	33	0.171	0.58	0.195	1.066	0.040	0.486	0.085	0.151	0.090	1773	832	0.05560	0.047	-0.977	1.526	0.590
350PDT150-30	0.0312	33	0.203	0.69	0.409	1.421	0.045	0.470	0.088	0.326	0.146	2887	781	0.06573	0.101	-0.869	1.731	0.748
362PDT150-30	0.0312	33	0.206	0.70	0.443	1.464	0.045	0.468	0.088	0.354	0.154	3042	755	0.06699	0.109	-0.858	1.760	0.763
400PDT150-30	0.0312	33	0.218	0.74	0.553	1.592	0.046	0.461	0.088	0.446	0.178	3526	683	0.07079	0.137	-0.825	1.851	0.802
550PDT150-30	0.0312	33	0.265	0.90	1.157	2.090	0.050	0.435	0.090	0.979	0.241	4766	495	0.08597	0.284	-0.716	2.251	0.899
600PDT150-30	0.0312	33	0.281	0.96	1.422	2.251	0.051	0.427	0.090	1.136	0.244	4818	454	0.09104	0.347	-0.686	2.392	0.918

1. Web-height to thickness ratio exceeds 200. Web Stiffeners are required at all support points and concentrated loads.
2. Web-depth to thickness ratio exceeds 260. Web stiffeners are required at all bearing and intermediate locations, and no web holes are permitted in non-composite conditions

For additional information, please call (305) 634-0012 or visit our website www.ramsteel framing.com



Product Data – ProSTUD & ProTRAK

Section Properties

Section Properties Table Notes

1. Section properties were determined in accordance with AISI S100-07, North American Specification for Design of Cold-Formed Steel Structural Members.
2. Effective properties incorporate the strength increase from the cold work of forming as applicable per AISI A7.2.
3. Tabulated gross properties including torsional properties are based on full-unreduced cross section of the tracks.
4. For deflection calculations, use the effective moment of inertia.
5. Allowable moment includes cold-work of forming.
6. Web depth for track sections is equal to the nominal height plus 2 times the design thickness plus the bend radius. Hems on non-structural rack sections are ignored.

Non-Structural (PT) ProTRAK® (2" Leg) Section Properties

Section	Design Thickness (in)	F (ksi)	Gross Section Properties						Effective Section Properties at Fy						Torsional Properties			
			Area Weight I		Rx	ly	Ry	Ae	I	Sx	Ma	Vag	Jx1000	Cw	Xo	Ro		
			(in2)	(lb/ft)	(in4)	(in)	(in4)	(in)	(in2)	(in4)	(in3)	(in-lbs)	(lb)	(in4)	(in6)	(in)	(in)	β
162PDT200-15	0.0158	50	0.089	0.30	0.050	0.752	0.039	0.663	0.020	0.025	0.015	455	222	0.00739	0.020	-1.579	1.870	0.287
250PDT200-15	0.0158	50	0.103	0.35	0.124	1.098	0.045	0.662	0.021	0.064	0.024	720	143	0.00854	0.052	-1.431	1.921	0.445
350PDT200-15 ¹	0.0158	50	0.118	0.40	0.256	1.470	0.050	0.650	0.021	0.127	0.034	1025	101	0.00986	0.111	-1.297	2.066	0.606
362PDT200-15 ¹	0.0158	50	0.120	0.41	0.277	1.516	0.051	0.648	0.021	0.137	0.036	1063	98	0.01002	0.120	-1.282	2.088	0.623
400PDT200-15 ¹	0.0158	50	0.126	0.43	0.344	1.650	0.052	0.642	0.021	0.168	0.039	1178	89	0.01052	0.151	-1.240	2.162	0.671
550PDT200-15 ²	0.0158	50	0.150	0.51	0.707	2.170	0.057	0.617	0.021	0.325	0.055	1637	64	0.01249	0.314	-1.098	2.509	0.809
600PDT200-15 ²	0.0158	50	0.158	0.54	0.864	2.338	0.058	0.608	0.021	0.389	0.060	1789	59	0.01315	0.383	-1.058	2.638	0.839
162PDT200-19	0.0200	50	0.112	0.38	0.064	0.754	0.049	0.662	0.031	0.034	0.024	707	421	0.01499	0.026	-1.576	1.868	0.288
250PDT200-19	0.0200	50	0.130	0.44	0.157	1.099	0.057	0.661	0.032	0.094	0.037	1119	289	0.01733	0.066	-1.429	1.920	0.446
350PDT200-19	0.0200	50	0.150	0.51	0.325	1.472	0.063	0.649	0.032	0.191	0.053	1592	206	0.01999	0.141	-1.295	2.065	0.607
362PDT200-19	0.0200	50	0.152	0.52	0.351	1.517	0.064	0.647	0.032	0.205	0.055	1651	199	0.02033	0.152	-1.280	2.088	0.624
400PDT200-19	0.0200	50	0.160	0.54	0.436	1.651	0.066	0.642	0.032	0.251	0.061	1829	180	0.02133	0.191	-1.238	2.161	0.672
550PDT200-19 ²	0.0200	50	0.190	0.65	0.895	2.171	0.072	0.616	0.033	0.484	0.085	2542	130	0.02533	0.397	-1.096	2.509	0.809
600PDT200-19 ²	0.0200	50	0.200	0.68	1.094	2.339	0.074	0.607	0.033	0.580	0.093	2780	119	0.02666	0.485	-1.056	2.637	0.840
162PDT200-30	0.0312	33	0.175	0.60	0.101	0.758	0.076	0.660	0.081	0.067	0.052	1028	610	0.05687	0.040	-1.570	1.864	0.291
250PDT200-30	0.0312	33	0.203	0.69	0.246	1.103	0.088	0.659	0.086	0.170	0.094	1862	832	0.06573	0.103	-1.423	1.917	0.449
350PDT200-30	0.0312	33	0.234	0.80	0.509	1.475	0.098	0.647	0.088	0.365	0.154	3039	781	0.07585	0.219	-1.289	2.063	0.610
362PDT200-30	0.0312	33	0.238	0.81	0.549	1.520	0.099	0.645	0.089	0.397	0.160	3159	755	0.07712	0.237	-1.274	2.086	0.627
400PDT200-30	0.0312	33	0.249	0.85	0.682	1.654	0.102	0.639	0.089	0.502	0.176	3480	683	0.08091	0.297	-1.232	2.160	0.674
550PDT200-30	0.0312	33	0.296	1.01	1.399	2.174	0.112	0.614	0.091	1.091	0.240	4747	495	0.09610	0.617	-1.091	2.508	0.811
600PDT200-30	0.0312	33	0.312	1.06	1.710	2.342	0.114	0.605	0.091	1.353	0.262	5170	454	0.10116	0.754	-1.051	2.637	0.841

1. Web-height to thickness ratio exceeds 200. Web Stiffeners are required at all support points and concentrated loads.
2. Web-depth to thickness ratio exceeds 260. Web stiffeners are required at all bearing and intermediate locations, and no web holes are permitted in non-composite conditions

For additional information, please call (305) 634-0012 or visit our website www.ramsteel framing.com



Product Data – ProSTUD & ProTRAK

Section Properties
Section Properties Table Notes

1. Section properties were determined in accordance with AISI S100-07, North American Specification for Design of Cold-Formed Steel Structural Members.
2. Effective properties incorporate the strength increase from the cold work of forming as applicable per AISI A7.2.
3. Tabulated gross properties including torsional properties are based on full-unreduced cross section of the tracks.
4. For deflection calculations, use the effective moment of inertia.
5. Allowable moment includes cold-work of forming.
6. Web depth for track sections is equal to the nominal height plus 2 times the design thickness plus the bend radius. Hems on non-structural rack sections are ignored.

Non-Structural (PT) ProTRAK® (2-1/2" Leg) Section Properties

Section	Design Thickness (in)	F (ksi)	Gross Section Properties						Effective Section Properties at Fy					Torsional Properties				
			Area Weight Ix (in ²) (lb/ft) (in ⁴)		Rx (in)	Iy (in ⁴)	Ry (in)	Ae (in ²)	Ix (in ⁴)	Sx Ma Vag (in ³) (in-lbs) (lb)	Ix1000 (in ⁴)	Cw (in ⁶)	Xo (in)	Ro (in)	β			
162PDT250-15	0.0158	50	0.105	0.36	0.061	0.766	0.071	0.824	0.020	0.027	0.015	455	222	0.00871	0.038	-2.058	2.345	0.230
250PDT250-15	0.0158	50	0.118	0.40	0.150	1.123	0.082	0.831	0.021	0.066	0.024	725	143	0.00986	0.096	-1.892	2.352	0.353
350PDT250-15 ¹	0.0158	50	0.134	0.46	0.306	1.510	0.091	0.825	0.021	0.132	0.035	1034	101	0.01117	0.203	-1.737	2.445	0.495
362PDT250-15 ¹	0.0158	50	0.136	0.46	0.330	1.557	0.092	0.823	0.021	0.142	0.036	1073	98	0.01134	0.220	-1.720	2.462	0.512
400PDT250-15 ¹	0.0158	50	0.142	0.48	0.409	1.696	0.095	0.819	0.021	0.174	0.040	1189	89	0.01183	0.275	-1.670	2.517	0.560
550PDT250-15 ²	0.0158	50	0.166	0.56	0.829	2.235	0.105	0.795	0.021	0.337	0.055	1654	64	0.01380	0.570	-1.500	2.807	0.714
600PDT250-15 ²	0.0158	50	0.174	0.59	1.009	2.409	0.108	0.787	0.021	0.404	0.060	1809	59	0.01446	0.697	-1.452	2.921	0.753
162PDT250-19	0.0200	50	0.132	0.45	0.078	0.768	0.090	0.823	0.031	0.037	0.023	698	421	0.01766	0.048	-2.055	2.343	0.231
250PDT250-19	0.0200	50	0.150	0.51	0.190	1.125	0.103	0.830	0.032	0.099	0.037	1113	289	0.01999	0.121	-1.890	2.351	0.354
350PDT250-19	0.0200	50	0.170	0.58	0.388	1.511	0.115	0.824	0.032	0.199	0.053	1589	206	0.02266	0.257	-1.735	2.444	0.496
362PDT250-19	0.0200	50	0.172	0.59	0.419	1.558	0.117	0.822	0.032	0.213	0.055	1649	199	0.02299	0.278	-1.718	2.461	0.513
400PDT250-19	0.0200	50	0.180	0.61	0.518	1.697	0.120	0.818	0.032	0.261	0.061	1829	180	0.02399	0.348	-1.668	2.517	0.561
550PDT250-19 ²	0.0200	50	0.210	0.71	1.050	2.236	0.133	0.795	0.033	0.505	0.085	2548	130	0.02799	0.721	-1.498	2.806	0.715
600PDT250-19 ²	0.0200	50	0.220	0.75	1.278	2.410	0.136	0.786	0.033	0.605	0.093	2788	119	0.02933	0.881	-1.450	2.920	0.754
162PDT250-30	0.0312	33	0.206	0.70	0.123	0.772	0.139	0.821	0.082	0.073	0.054	1059	610	0.06699	0.075	-2.048	2.338	0.233
250PDT250-30	0.0312	33	0.234	0.80	0.298	1.129	0.160	0.828	0.086	0.186	0.097	1926	832	0.07585	0.190	-1.883	2.347	0.356
350PDT250-30	0.0312	33	0.265	0.90	0.608	1.515	0.179	0.822	0.089	0.401	0.151	2987	781	0.08597	0.402	-1.729	2.441	0.498
362PDT250-30	0.0312	33	0.269	0.92	0.656	1.562	0.181	0.820	0.089	0.436	0.157	3097	755	0.08724	0.435	-1.712	2.458	0.515
400PDT250-30	0.0312	33	0.281	0.96	0.812	1.701	0.187	0.816	0.090	0.551	0.173	3425	683	0.09104	0.543	-1.662	2.514	0.563
550PDT250-30	0.0312	33	0.327	1.11	1.641	2.239	0.206	0.793	0.091	1.190	0.239	4727	495	0.10622	1.124	-1.493	2.805	0.717
600PDT250-30	0.0312	33	0.343	1.17	1.997	2.413	0.211	0.784	0.092	1.473	0.261	5162	454	0.11128	1.373	-1.444	2.919	0.755

1. Web-height to thickness ratio exceeds 200. Web Stiffeners are required at all support points and concentrated loads.
2. Web-depth to thickness ratio exceeds 260. Web stiffeners are required at all bearing and intermediate locations, and no web holes are permitted in non-composite conditions

For additional information, please call (305) 634-0012 or visit our website www.ramsteel framing.com



Product Data – ProSTUD & ProTRAK

Section Properties

Section Properties Table Notes

1. Section properties were determined in accordance with AISI S100-07, North American Specification for Design of Cold-Formed Steel Structural Members.
2. Effective properties incorporate the strength increase from the cold work of forming as applicable per AISI A7.2.
3. Tabulated gross properties including torsional properties are based on full-unreduced cross section of the tracks.
4. For deflection calculations, use the effective moment of inertia.
5. Allowable moment includes cold-work of forming.
6. Web depth for track sections is equal to the nominal height plus 2 times the design thickness plus the bend radius. Hems on non-structural rack sections are ignored.

Non-Structural (PT) ProTRAK® (3" Leg) Section Properties

Section	Design Thickness (in)	F (ksi)	Gross Section Properties						Effective Section Properties at Fy					Torsional Properties				
			Area (in ²)	Weight (lb/ft) (in ⁴)	Rx (in)	Iy (in ⁴)	Ry (in)	Ae (in ²)	Ix (in ⁴)	Sx (in ³)	Ma (in-lbs)	Vag (lb)	Jx1000 (in ⁴)	Cw (in ⁶)	Xo (in)	Ro (in)	β	
162PDT300-15	0.0158	50	0.120	0.41	0.073	0.776	0.116	0.981	0.020	0.027	0.016	465	222	0.01002	0.063	-2.542	2.834	0.195
250PDT300-15	0.0158	50	0.134	0.46	0.175	1.143	0.133	0.996	0.021	0.067	0.025	748	143	0.01117	0.158	-2.363	2.807	0.291
350PDT300-15 ¹	0.0158	50	0.150	0.51	0.356	1.540	0.149	0.996	0.021	0.135	0.035	1051	101	0.01249	0.334	-2.191	2.858	0.412
362PDT300-15 ¹	0.0158	50	0.152	0.52	0.384	1.589	0.151	0.995	0.021	0.145	0.036	1090	98	0.01265	0.361	-2.172	2.869	0.427
400PDT300-15 ¹	0.0158	50	0.158	0.54	0.474	1.732	0.155	0.992	0.021	0.178	0.040	1204	89	0.01315	0.450	-2.116	2.909	0.471
550PDT300-15 ²	0.0158	50	0.182	0.62	0.951	2.287	0.172	0.973	0.021	0.338	0.056	1664	64	0.01512	0.930	-1.921	3.142	0.626
600PDT300-15 ²	0.0158	50	0.190	0.64	1.153	2.467	0.177	0.965	0.021	0.412	0.061	1818	59	0.01578	1.136	-1.865	3.239	0.669
162PDT300-19	0.0200	50	0.152	0.52	0.092	0.778	0.147	0.981	0.031	0.049	0.022	727	421	0.02033	0.080	-2.540	2.831	0.195
250PDT300-19	0.0200	50	0.170	0.58	0.223	1.144	0.168	0.995	0.032	0.102	0.037	1108	289	0.02266	0.201	-2.360	2.806	0.292
350PDT300-19	0.0200	50	0.190	0.65	0.451	1.542	0.188	0.995	0.032	0.205	0.053	1587	206	0.02533	0.423	-2.189	2.856	0.413
362PDT300-19	0.0200	50	0.192	0.65	0.487	1.590	0.190	0.994	0.032	0.221	0.055	1647	199	0.02566	0.457	-2.169	2.868	0.428
400PDT300-19	0.0200	50	0.200	0.68	0.601	1.734	0.196	0.991	0.033	0.271	0.060	1790	180	0.02666	0.570	-2.113	2.908	0.472
550PDT300-19 ²	0.0200	50	0.230	0.78	1.204	2.289	0.217	0.972	0.033	0.576	0.086	2522	130	0.03066	1.177	-1.919	3.141	0.627
600PDT300-19 ²	0.0200	50	0.240	0.82	1.461	2.468	0.223	0.964	0.033	0.650	0.094	2727	119	0.03199	1.438	-1.863	3.239	0.669
162PDT300-30	0.0312	33	0.238	0.81	0.146	0.783	0.228	0.979	0.082	0.078	0.055	1081	610	0.07712	0.125	-2.532	2.826	0.197
250PDT300-30	0.0312	33	0.265	0.90	0.350	1.149	0.261	0.993	0.087	0.199	0.100	1973	832	0.08597	0.315	-2.354	2.801	0.294
350PDT300-30	0.0312	33	0.296	1.01	0.707	1.546	0.292	0.993	0.089	0.432	0.149	2945	781	0.09610	0.661	-2.182	2.853	0.415
362PDT300-30	0.0312	33	0.300	1.02	0.762	1.594	0.295	0.992	0.089	0.470	0.155	3056	755	0.09736	0.714	-2.163	2.864	0.430
400PDT300-30	0.0312	33	0.312	1.06	0.941	1.737	0.305	0.989	0.090	0.593	0.171	3387	683	0.10116	0.891	-2.107	2.905	0.474
550PDT300-30	0.0312	33	0.359	1.22	1.883	2.292	0.337	0.970	0.092	1.278	0.238	4710	495	0.11635	1.836	-1.913	3.139	0.629
600PDT300-30	0.0312	33	0.374	1.27	2.285	2.471	0.346	0.962	0.092	1.580	0.261	5152	454	0.12141	2.241	-1.857	3.237	0.671

1. Web-height to thickness ratio exceeds 200. Web Stiffeners are required at all support points and concentrated loads.
2. Web-depth to thickness ratio exceeds 260. Web stiffeners are required at all bearing and intermediate locations, and no web holes are permitted in non-composite conditions

For additional information, please call (305) 634-0012 or visit our website www.ramsteel framing.com



Product Data – ProSTUD & ProTRAK

Which limiting height table?

Composite Assemblies

Composite limiting height data can be applied to walls where gypsum board is installed on both flanges of the stud for the full height of the wall. ProSTUD composite data is based on the 2009 International Building Code and was tested and analyzed in accordance with the most recent version of AC86 (2010).

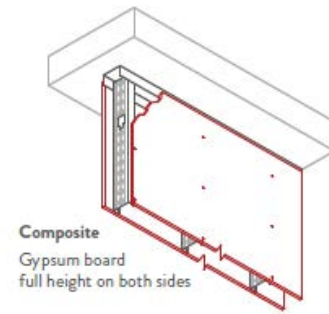

Non-Composite Assemblies

Non-Composite conditions are common in all structures. These assemblies occur when the gypsum board stops at the ceiling level, but the stud continues to the deck. The pictures below show some variations of braced non-composite walls.

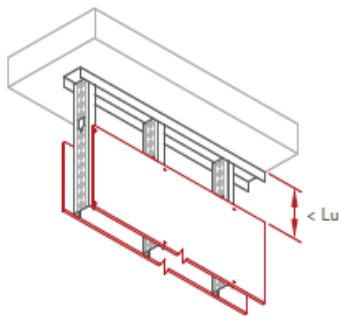

Non-Composite FULLY BRACED
Unbraced length is less than Lu

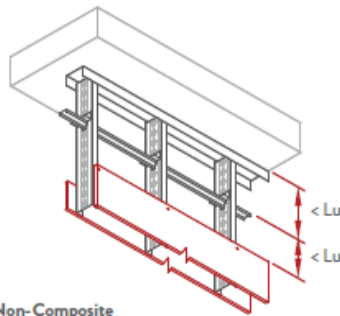

Non-Composite FULLY BRACED
Bracing spacing above gypsum is less than Lu

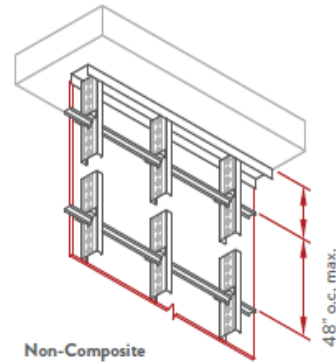

Non-Composite BRACED AT 48" o.c.
Gypsum board placed on only one side

Other Assemblies

For assemblies not listed above, the conditions may vary greatly depending on the building requirements. While the provided non-composite tables may be used conservatively, please consult an architecture before performing any work.

For additional information, please call (305) 634-0012 or visit our website www.ramsteel framing.com



Product Data – ProSTUD & ProTRAK Limiting Wall Heights

Interior Non-Structural Composite Table Notes

1. Allowable composite limiting heights are calculated using ICC-ES AC86-2010. In accordance with current building codes and AISI design standards, the 1/3 Stress Increase for strength was not used.
2. The composite limiting heights provided in the tables are based on a single layer of Type X Gypsum Board from the following manufacturers: American, CertainTeed, Georgia Pacific, Lafarge, National, Temple Inland, and USG.
3. The gypsum board must be applied full height in the vertical orientation to each stud flange and installed in accordance with ASTM C754-2004 using minimum No. 6 Type S Drywall screws spaced a minimum of 12-in on-center to the framing members.
4. No fasteners are required for attaching the stud to the track except as detailed in ASTM C754-2004.
5. Stud end bearing must be a minimum of 1 inch.
6. Minimum material yield strength equals 50 ksi for 15-mil and 65 ksi for 19-mil studs.
7. 'f' adjacent to the height value indicates that flexural stress controls the allowable wall height.
8. 's' adjacent to the height value indicates that shear/end reaction controls the allowable wall height.

Interior Composite data with 1 layer 5/8" Type X Gypsum Board

Stud Member	Spacing inches	Lateral Load (psf)								
		5 psf			7.5 psf			10 psf		
		L/120	L/240	L/360	L/120	L/240	L/360	L/120	L/240	L/360
162PS125-15	12	14' 1"	11' 7"	10' 1"	12' 3"	10' 1"	8' 7"	11' 2"	9' 1"	---
	16	12' 9"	10' 6"	9' 0"	11' 2"	9' 1"	---	10' 2"	8' 1"	---
	24	11' 2"	9' 1"	---	9' 9"	---	---	8' 5"	---	---
162PS125-19	12	14' 10"	12' 11"	11' 2"	12' 11"	11' 3"	9' 9"	11' 9"	10' 3"	8' 8"
	16	13' 5"	11' 8"	10' 1"	11' 9"	10' 3"	8' 8"	10' 8"	9' 2"	---
	24	11' 9"	10' 3"	8' 8"	10' 3"	8' 8"	---	9' 2"	---	---
250PS125-15	12	17' 2"	14' 8"	13' 0"	15' 0"	12' 10"	11' 4"	13' 3" f	11' 8"	10' 4"
	16	15' 7"	13' 4"	11' 9"	13' 3" f	11' 8"	10' 4"	11' 5" f	10' 7"	9' 1"
	24	13' 3" f	11' 8"	10' 4"	10' 10" f	10' 2"	8' 6"	9' 4" f	8' 11"	---
250PS125-19	12	18' 1"	15' 9"	14' 0"	15' 9"	13' 9"	12' 3"	14' 4"	12' 6"	11' 1"
	16	16' 5"	14' 4"	12' 8"	14' 4"	12' 6"	11' 1"	13' 0"	11' 4"	10' 1"
	24	14' 4"	12' 6"	11' 1"	12' 6" f	10' 11"	9' 8"	11' 5"	9' 11"	8' 7"
350PS125-15	12	21' 4" f	16' 11"	15' 0"	17' 5" f	14' 9"	13' 1"	15' 1" f	13' 5"	11' 10"
	16	18' 6" f	15' 4"	13' 7"	15' 1" f	13' 5"	11' 10"	13' 1" f	12' 2"	10' 8"
	24	15' 1" f	13' 5"	11' 10"	12' 4" f	11' 8"	10' 2"	10' 8" f	10' 5"	9' 1"
350PS125-19	12	22' 10"	18' 1"	15' 10"	19' 11"	15' 10"	13' 10"	18' 1"	14' 4"	12' 7"
	16	20' 9"	16' 5"	14' 4"	18' 1"	14' 4"	12' 7"	16' 2" f	13' 1"	11' 4"
	24	18' 1"	14' 4"	12' 7"	15' 3" f	12' 7"	10' 11"	13' 3" f	11' 4"	9' 10"
362PS125-15	12	21' 6"	17' 1"	14' 11"	18' 4" f	14' 11"	13' 0"	15' 10" f	13' 7"	11' 10"
	16	19' 5" f	15' 6"	13' 7"	15' 10" f	13' 7"	11' 10"	13' 9" f	12' 4"	10' 7"
	24	15' 10" f	13' 7"	11' 10"	12' 1"	11' 10"	10' 1"	11' 2" f	10' 7"	9' 0"
362PS125-19	12	23' 3"	18' 5"	16' 1"	20' 4"	16' 1"	14' 1"	18' 5"	14' 8"	12' 10"
	16	21' 1"	16' 9"	14' 8"	18' 5"	14' 8"	12' 10"	16' 7" f	13' 4"	11' 7"
	24	18' 5"	14' 8"	12' 10"	15' 8" f	12' 10"	11' 1"	13' 7" f	11' 7"	9' 11"
400PS125-15	12	22' 8"	18' 0"	15' 9"	19' 1" f	15' 9"	13' 9"	16' 6" f	14' 4"	12' 6"
	16	20' 3" f	16' 4"	14' 4"	16' 6" f	14' 4"	12' 6"	14' 4" f	13' 0"	11' 3"
	24	16' 6" f	14' 4"	12' 6"	13' 6" f	12' 6"	10' 8"	11' 8" f	11' 3"	9' 6"
400PS125-19	12	24' 4"	20' 2"	17' 9"	21' 3"	17' 8"	15' 6"	19' 4"	16' 0"	14' 1"
	16	22' 2"	18' 4"	16' 1"	19' 4"	16' 0"	14' 1"	17' 7" f	14' 7"	12' 9"
	24	19' 4"	16' 0"	14' 1"	16' 6" f	14' 0"	12' 4"	14' 4" f	12' 9"	11' 0"
550PS125-15	12	26' 11" f	22' 9"	20' 3"	22' 0" f	19' 11"	17' 9"	19' 0" f	18' 1"	16' 1"
	16	23' 4" f	20' 8"	18' 5"	19' 0" f	18' 1"	16' 1"	16' 6" f	16' 5"	14' 7"
	24	19' 0" f	18' 1"	16' 1"	15' 7" f	15' 7" f	14' 1"	13' 6" f	13' 6" f	12' 9"
550PS125-19	12	31' 10"	25' 4"	22' 1"	27' 10" f	22' 1"	19' 4"	24' 3" f	20' 1"	17' 6"
	16	28' 11"	23' 0"	20' 1"	24' 3" f	20' 1"	17' 6"	21' 0" f	18' 3"	15' 11"
	24	24' 3" f	20' 1"	17' 6"	19' 10" f	17' 6"	15' 3"	17' 2" f	15' 11"	13' 9"
600PS125-15	12	27' 10" f	24' 2"	21' 5"	22' 9" f	21' 1"	18' 1"	19' 1" f	19' 2"	17' 0"
	16	24' 1" f	21' 11"	19' 5"	19' 8" f	19' 2"	17' 0"	17' 1" f	17' 1" f	15' 5"
	24	19' 8" f	19' 2"	17' 0"	16' 1" f	16' 1" f	14' 9"	13' 11" f	13' 11" f	13' 4"
600PS125-19	12	32' 0"	26' 5"	23' 2"	28' 0"	23' 1"	20' 3"	24' 9" f	21' 0"	18' 5"
	16	29' 1"	24' 0"	21' 1"	24' 9" f	21' 0"	18' 5"	21' 5" f	19' 1"	16' 9"
	24	24' 9" f	21' 0"	18' 5"	20' 3" f	18' 4"	16' 1"	17' 6" f	16' 8"	14' 4"

For additional information, please call (305) 634-0012 or visit our website www.ramsteel framing.com